

1.Features

- UMTS, LTE Band
- PCB Soldering Re-flow
- Wide Operation Temperature Range -40~ 85°C
- Compact Package Design for PCB Applications

2.Dimensions Unit:mm

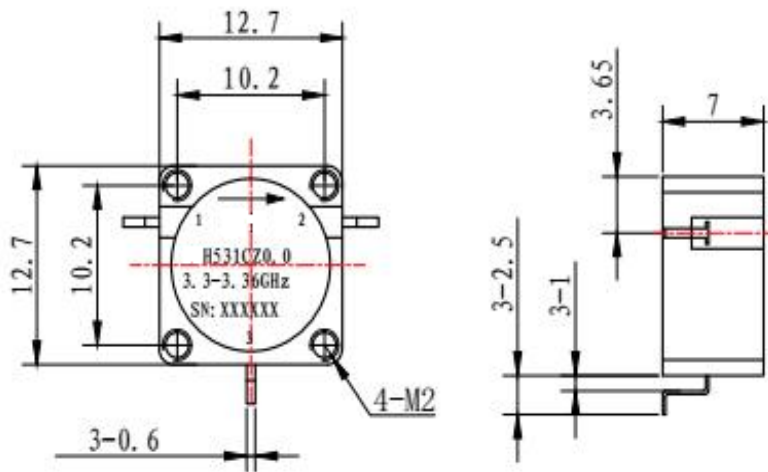

3.Specifications

Part No.	Frequency (GHz)		Center Frequency	Bandwidth	Isolation	INS LOSS	VSWR	Power	IMD (@2X43dBm)
	F1	F2	(GHz)	(GHz)	(dB) MIN	(dB) MAX	(dB) MAX	(W)	(-dBc) MAX
H531C[3.3-3.36]MHz	3.300	3.360	3.3300	0.060	22	0.3	1.17	100	
H531C[3400-3700]MHz	3.400	3.700	3.5500	0.300	21	0.4	1.2	50	
H531C[5790-5890]MHz	5.790	5.890	5.8500	0.100	23	0.3	1.17	20	